

Pneumatic Speed Adjustment

For UG 5.7, 8, and 10 Lever Governors



- Economical
- Positive Control
- Separate Housing
- Easily Adjusted
- Good Accuracy

APPLICATIONS

Remote speed adjustment is possible by using this pneumatic speed adjustment unit. It is mounted on top of the UG 5.7, 8, and 10 Lever Governors in a separate housing.

The unit operates on direct air pressure. Level and range adjustments are easily made to match the speed setting of the governor with the air pressure signal.

Required air supply is 3 to 15 psi or 10 to 50 psi. Hysteresis of the speed setting is 0.5%.

The cast aluminum housing accepts solenoid, pneumatic, or low-lube shutdown devices.

MANUAL SPEED SETTING

A manual speed setting feature is available as an auxiliary. The screw permits setting speed at the governor. The pneumatic speed setting cannot change the speed of the governor to less than set on the manual setting.

3800 N. Wilson Ave.
 P.O. Box 3800
 Loveland, CO, U.S.A.
 80539-3800
 Ph: 1 970-663-3900
 Ph: 1 800-835-5182
 Fax: 1 970-962-7050

www.woodward.com



International Plants

- Australia**, New South Wales
- Brazil**, Campinas
- China**, Tianjin
- Germany**, Aken/Elbe & Kelbra
- India**, Haryana
- Japan**, Tomisato & Kobe
- Netherlands**, Hoofddorp & Rotterdam
- Singapore**
- United Kingdom**, Reading, England, & Prestwick, Scotland
- United States**, Colorado[2], Illinois[3], Michigan[2], New York, South Carolina, Tennessee

Regional Sales Offices

- Canada**, Québec
- China**, Beijing
- Czech Republic**, Plzen
- Germany**, Tettmang
- Korea**, Pusan
- Mexico**, Mexico City
- New Zealand**, Christchurch
- Poland**, Warsaw
- United Arab Emirates**, Abu Dhabi
- United States**, Alabama, California, Illinois, Pennsylvania, Texas, Washington

Distributors & Service

Woodward has a network of distributors and service facilities. For your nearest representative call 1 800-835-5182 or see the Worldwide Directory on our web site.

CORPORATE HEADQUARTERS/
 AIRCRAFT CONTROLS
 Rockford, IL, U.S.A.
 1 815-877-7441

This document is distributed for informational purposes only. It is not to be construed as creating or becoming part of any Woodward Governor Company contractual or warranty obligation unless expressly stated in a written sales contract.

© Woodward Governor Company, 1980
 All Rights Reserved

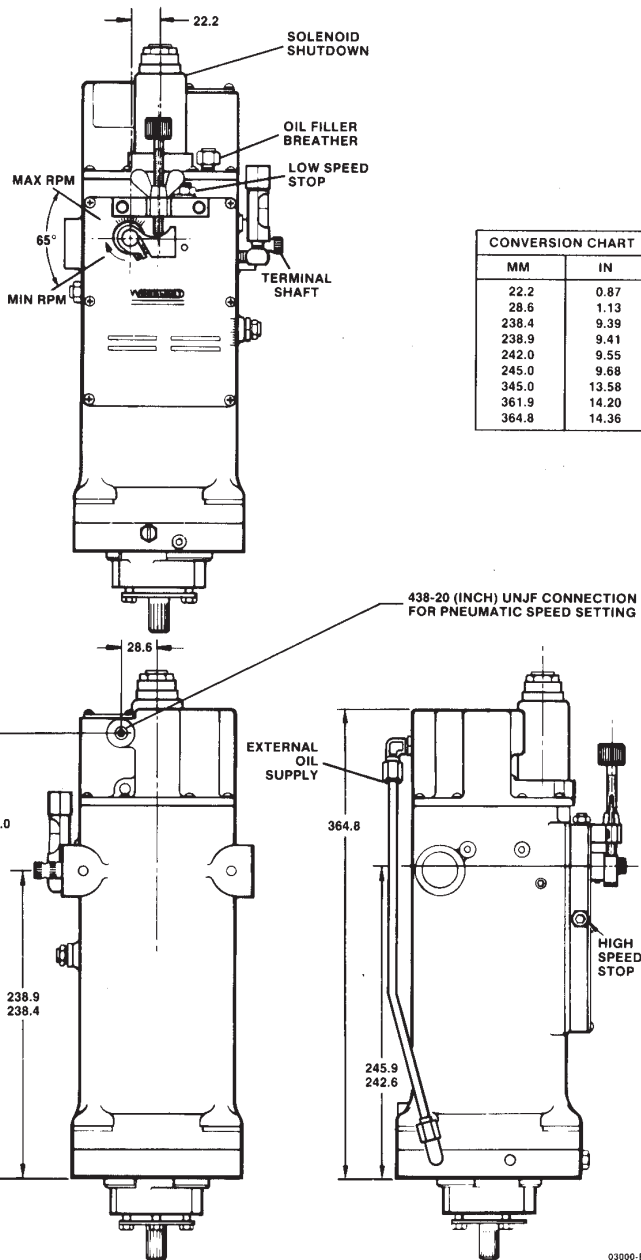

OUTLINE OF THE UG8 LEVER GOVERNOR WITH THE PNEUMATIC SPEED ADJUSTMENT AND MANUAL SPEED SETTING SCREW

(DO NOT USE FOR CONSTRUCTION)

For more information contact: